

Marcus Hamilton  
Portfolio Flatbook

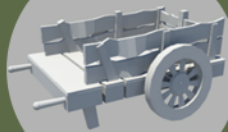
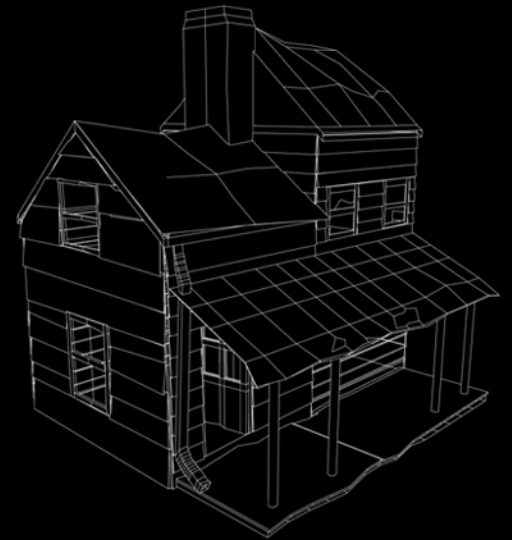

# OBJECT MODEL

## LANTERN

Simple model for original game scene.

- Model
- Material
- Lighting



Sketches • Texture

# OBJECT MODEL

## WAGON

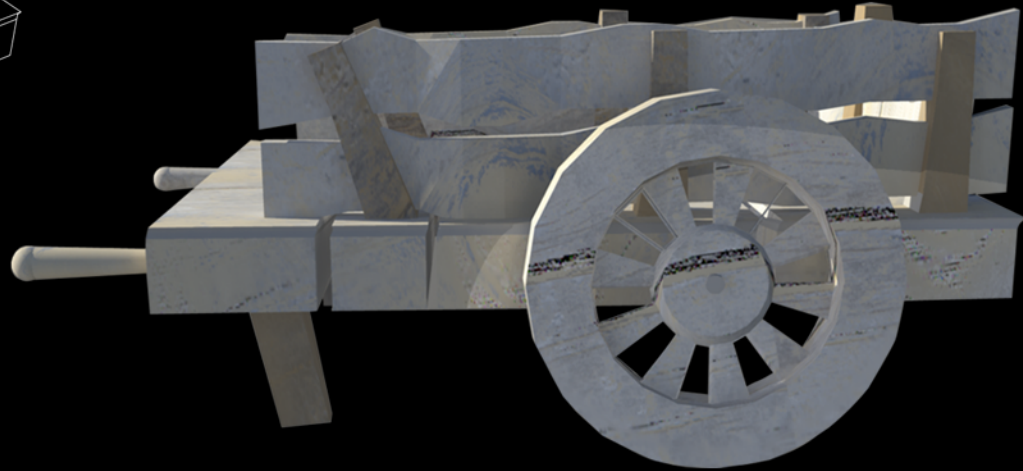
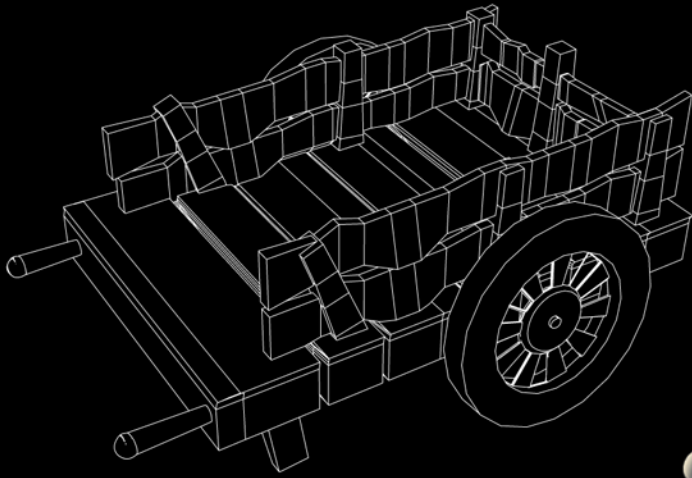

Additional model for original game scene.

- Model
- Material
- Lighting

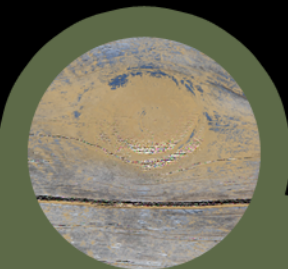
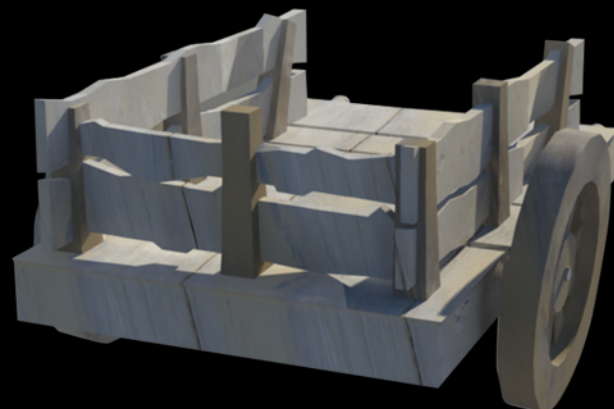
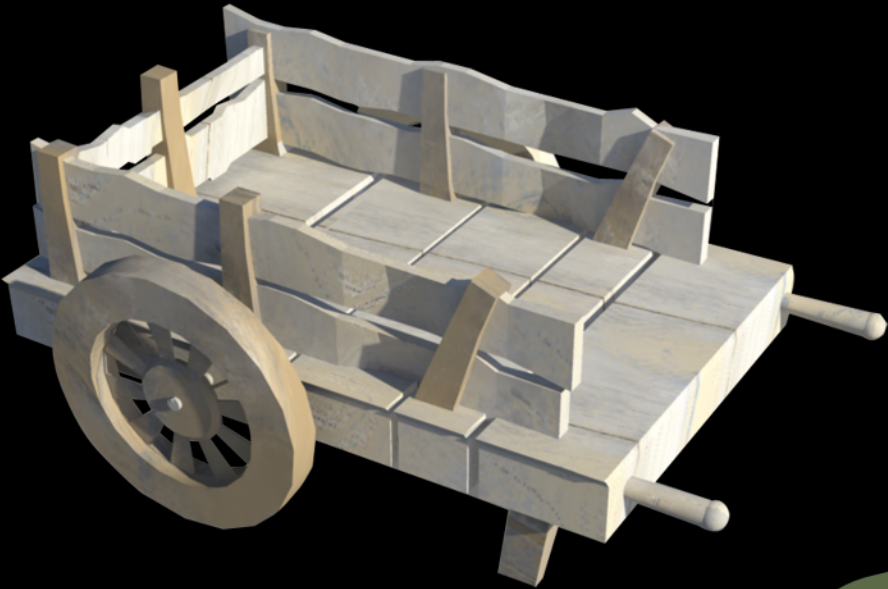

### Sketches • Texture

# OBJECT MODEL

## OLD TRUCK

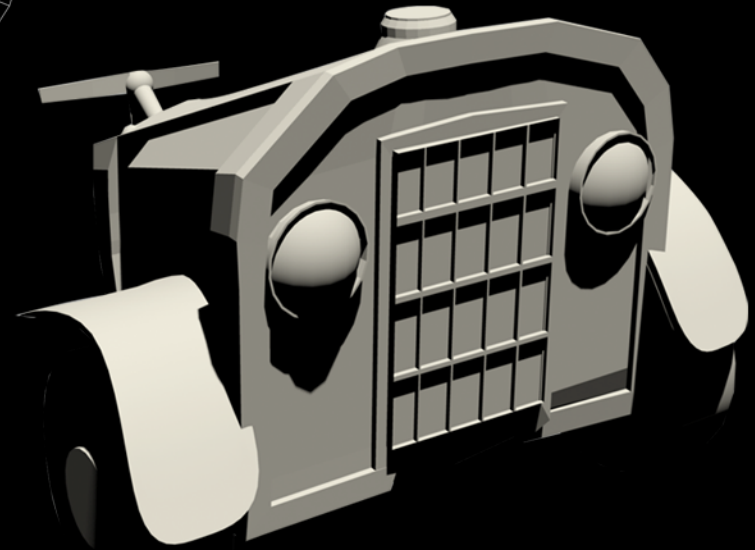
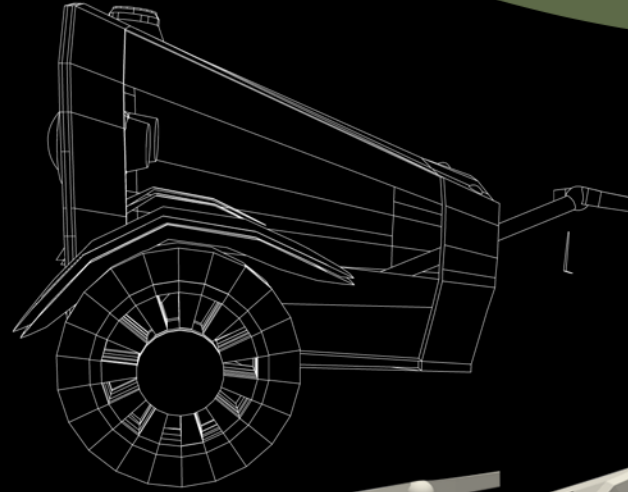
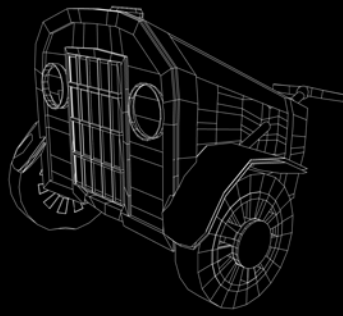

Additional model for original game scene.

- Model
- Material
- Lighting



# Sketches • Texture

# ENVIRONMENTAL LIGHTING

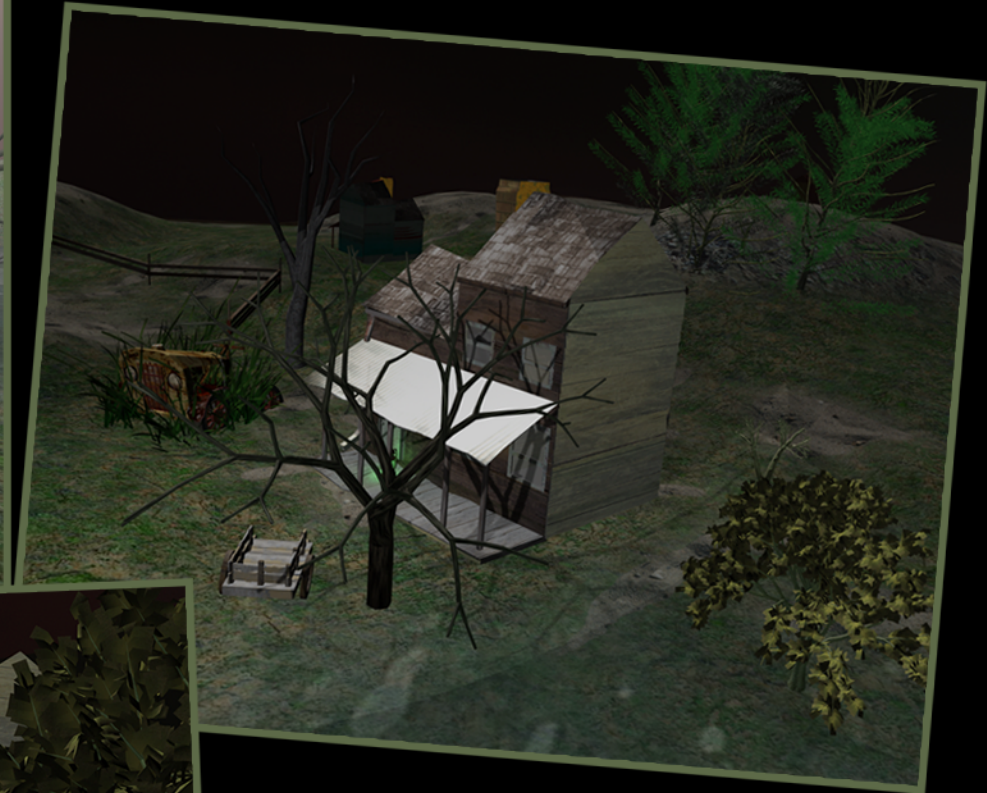
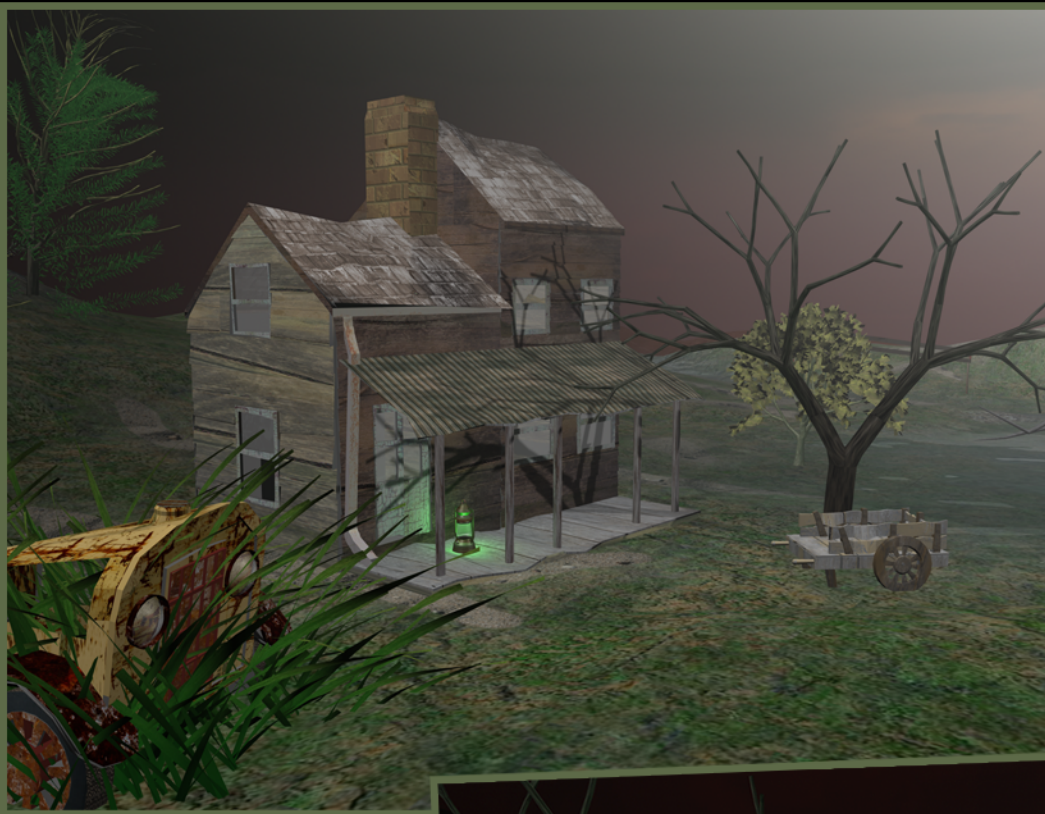

Environmental model/lighting  
for original game scene.

- Model
- Material
- Lighting